

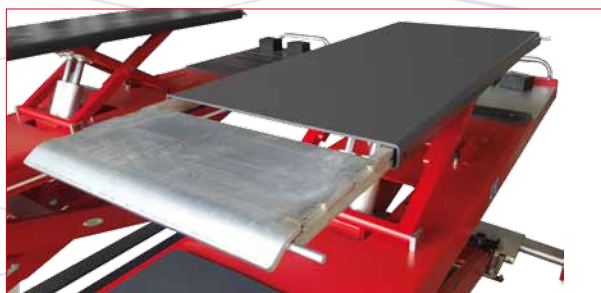

Electrohydraulic underwheel scissors type lift for total wheels geometry control "CT" with:

- rear oscillating platforms e recesses for front turntables.

Auxiliary wheel release lift "LT".



Lit table (LT) with double lifting cylinder and double extensions

Supplied with:

- ✓ **Automatic runway levelling system** with master/slave hydraulic circuit.
- ✓ **Self-lubricating bushings** on all rotating parts
- ✓ Set of 4 rubber pads

TECHNICAL DATA

Main lift capacity	5500 kg
"LT" capacity	4000 kg
Lifting time	45 s
Motor	400/230V - 3kW 3Ph - 50/60Hz
Main lift max. lifting height	2040/2020 mm
"LT" max. lifting height	500 mm
Lift minimum height	185/165 mm
Runboard length	4600/5200 mm



Adjustable recess for the turntable



Adjustable mechanical safety device



Easy drive on with short and sturdy ramps

DIMENSIONS

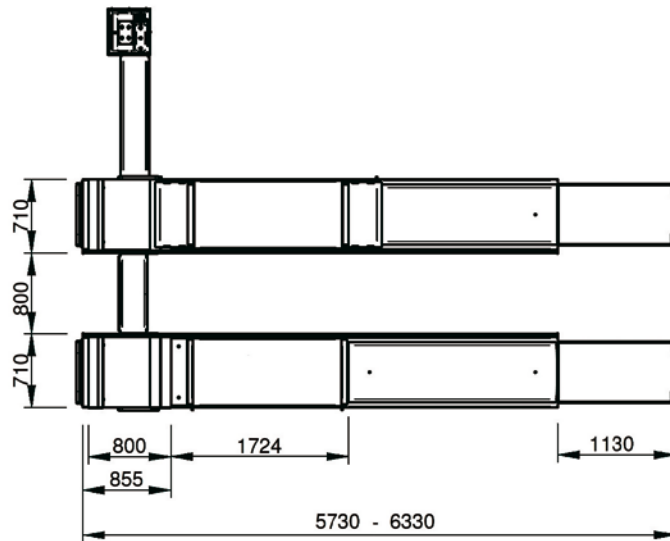
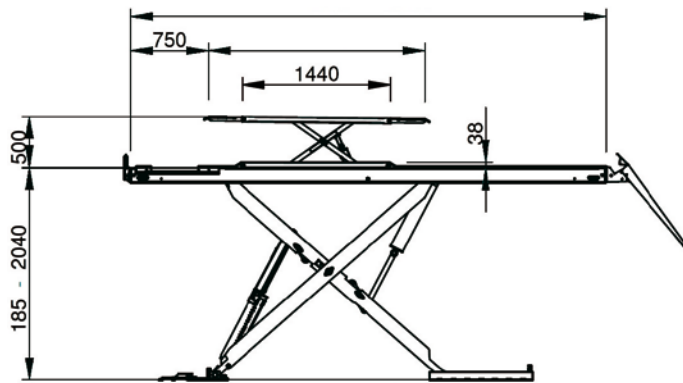

RECOMMENDED ACCESSORIES

- Pair of cross pieces and pads for off-road vehicles
- Kit for pit installations

