

 **CORGI**

A222

ALSO AVAILABLE IN **TI** VERSION
AUCH IN DER **TI** AUSFÜHRUNG

NEW



22" Tilting back tyre changer 

22" Reifenmontiermaschine mit pneumatisch kippbarer Montagesäule 

DIMENSIONS - ABMESSUNGEN

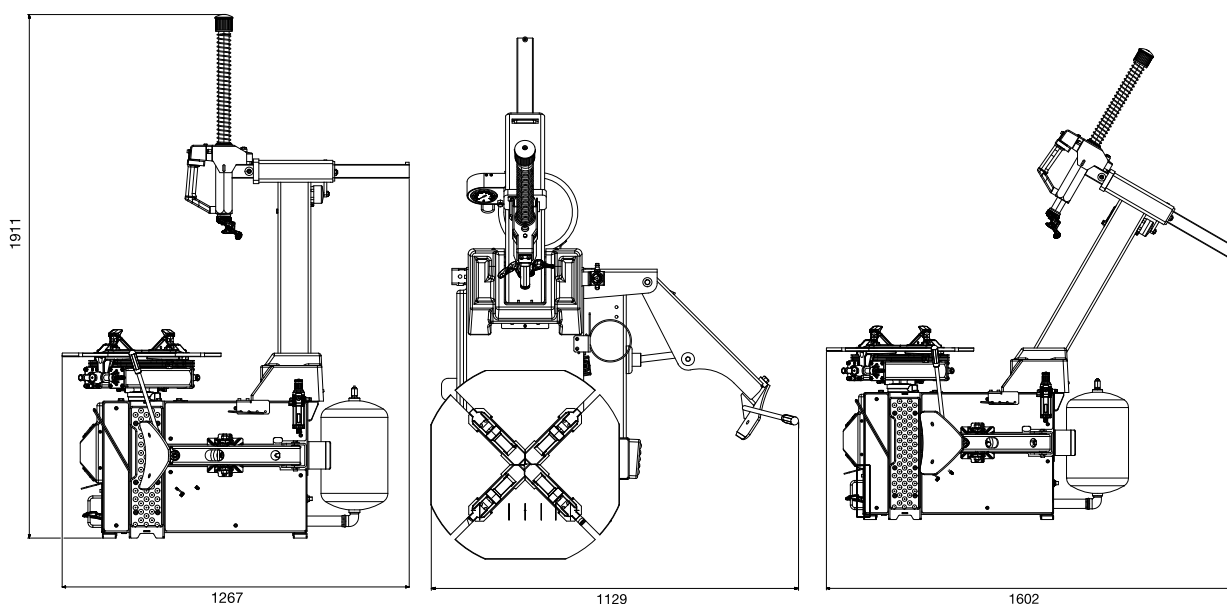

TECHNICAL DATA - TECHNISCHE DATEN

Power requirements	<i>Stromversorgung</i>	all power supply alle Stromversorgung
Operating pressure	<i>Betriebsdruck</i>	8-10 bar
Machine weight	<i>Gewicht</i>	214 kg - TI 224 kg
Max. dimensions (L x D x H)	<i>Max. Abmessungen (B x H x T)</i>	1200 x 1650 x 1900
Mounting head	<i>Montagekopf</i>	Standard
BEAD BREAKER TYPE		ABDRÜCKER
pedal operated		<i>Pedal betätigt</i>
single movement		<i>einzelne Bewegung</i>
double -acting cylinder		<i>doppeltwirkender Zylinder</i>
Bead breaker opening	<i>Abdrücker Öffnung</i>	45-320 mm
Bead breaker cylinder force	<i>Abdrückkraft Schaufel</i>	10 bar - 26.700 N
T.I. System	<i>TI-Version</i>	Yes - Ja
Positioning of vertical arm	<i>Positionierung des vertikalen Arms</i>	manual with spring manuell mit Feder
Vertical arm type	<i>Vertikalarm</i>	38 mm hexagonal shaft 38 mm Sechskantwelle
Tools tray	<i>Werkzeugfach</i>	No - Nein
Rim diameter range	<i>Spannbereich</i>	10" ÷ 22" (external-von aussen) 13" ÷ 25" (internal-von innen)
Max. tyre diameter	<i>Max. Reifendurchmesser</i>	1000 mm
Max. tyre width	<i>Max. Reifenbreite</i>	317,5 mm (12,5")
Rotation speed	<i>Drehgeschwindigkeit</i>	8,5 rpm 6-15 rpm MI

OPTIONAL ACCESSORIES

Wheel lifter	No
Bead pressing tool	Optional
SP2300	
Coupling kit on SP2300 for A222	8-11120038
SP2300 power unit	8-11100310
WDK mobile shaft	8-11100306
Standard mobile shaft	8-11100309
HELPER SX	
Bead pressing tool	8-11100100
Adapters	
Set of four motorcycle adapters	801258650
Set of four 8-24" adapters for 10-20" turntable	801263517

SONDERZUBEHÖR

<i>Radheber</i>	No
<i>Wulstniederhalter</i>	Auf Anfrage
SP2300	
<i>Anbaukit SP2300 für A222</i>	8-11120038
<i>SP2300 Mehrzweckvorrichtung</i>	8-11100310
<i>WDK Arm</i>	8-11100306
<i>Standard Arm</i>	8-11100309
HELPER SX	
<i>Wulstniederhalter</i>	8-11100100
Adapter	
<i>Motorradspannbacken</i>	801258650
<i>Satz Spannbacken 8-24"</i>	801263517

